

Specifications

Output Power HP (kW)	5 (3.7)
Phase	3 Phase
Pole	4 Pole
Frame Number	112M

Degrees of Protection	IP 55
Enclosure Construction	Totally-enclosed Fan-cooled
Thermal Class	Class F (155 °C)

Alignment	Vertical
Frame Material	Steel plate

Power Transmission	Direct-couple or Belt Driven
Direction of Rotation	Counterclockwise (CCW) viewed from shaft-end side



Connection Type	Terminal Block (6 Leads)
Coating Colour	Munsell N5.5 (Gray)
Conformed Standard	IEC 60034-1 & JEC-2137-2000



Voltage & Frequency	HT Type
	380~415V 50Hz 380~440V 60Hz (suitable for $\gamma$ - $\Delta$ starting)

Dimensions (mm)

Flange Number	Motor								
	D	IE	LA	LB	LC	LE	LG	LL	LZ
FF215	230	141	215	180 j6	250	4	16	351	14.5

Terminal Box			Shaft End						
KD	KG	KL	LR	Q	QK	S	T	U	W
PF 3/4	174	180	60	60	45	28 j6	7	4	8

Bearing No.		Approximated Weight (kg)	Approximated Packing Dimensions (LxWxH)	Gross Weight (kg)
Drive End	Opposite			
6207ZZ	6206ZZ	40	507 x 401 x 357	47

Connection & Connection Diagram

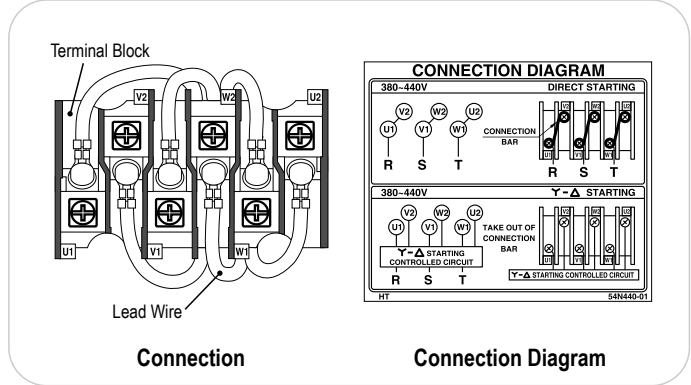

Circumstance Conditions

Ambient Temperature	-20 ~ +40°C
Ambient Humidity	95% RH or less
Operating Altitude	Less than 1,000m above sea level
Environment	No bursting / erosive gas or vapor

Motor Characteristics

Type	Hz	V	50% Load			75% Load			100% Load				Torque(%)		Is (A)	Inertia GD <sup>2</sup> (kg-m <sup>2</sup> )	
			(A)	Eff(%)	PF(%)	(A)	Eff(%)	PF(%)	(A)	Eff(%)	PF(%)	Speed (r/min)	Torque (kg-m)	Ts			Tm
HT	50	380	4.82	0.85	0.68	6.20	0.86	0.79	7.81	0.86	0.83	1420	2.54	266	289	46.2	0.056
		415	5.17	0.84	0.60	6.24	0.85	0.73	7.61	0.85	0.79	1430	2.52	316	344	50.5	
	60	380	4.35	0.84	0.77	5.83	0.86	0.84	7.62	0.85	0.87	1710	2.11	223	247	43.3	
		440	4.56	0.81	0.66	5.55	0.87	0.75	6.94	0.86	0.81	1730	2.08	298	335	50.1	